

# MicroRNAs control herpesviral dormancy

Xiufen Lei,<sup>1</sup> Zhiqiang Bai,<sup>1,3</sup> Fengchun Ye,<sup>1</sup> Yufei Huang<sup>1,4</sup> and Shou-Jiang Gao<sup>1,3,\*</sup>

<sup>1</sup>Tumor Virology Program; Greehey Children's Cancer Research Institute; and Department of Pediatrics, Microbiology and Immunology; Medicine; and Molecular Medicine; and Cancer Therapy and Research Center; The University of Texas Health Science Center at San Antonio; San Antonio, TX USA; <sup>2</sup>Tumor Virology Group; Wuhan Institute of Virology; Chinese Academy of Sciences; Wuhan, Hubei China; <sup>3</sup>Graduate University of the Chinese Academy of Sciences; Beijing, China; <sup>4</sup>Department of Electrical and Computer Engineering; The University of Texas at San Antonio; San Antonio, TX USA

Infections by herpesviruses are widespread in humans and are the causes for several important diseases. Gammaherpesvirus Kaposi's sarcoma-associated herpesvirus (KSHV) is etiologically associated with Kaposi's sarcoma (KS), a highly inflammatory and angiogenic cancer commonly found in AIDS patients.<sup>1</sup> KSHV is also associated with primary effusion lymphoma and a subset of multicentric Castleman's disease, two rare lymphoproliferative malignancies.

A hallmark of herpesviral infection is latency. During this phase of lifecycle, the virus produces no or limited viral proteins to evade host immune surveillance. Upon induction by host or environmental stimulus such as stress or immunosuppression, the virus switches into lytic replication, which is another phase of viral life cycle often associated with clinical diseases. Like other herpesviruses, KSHV also establishes a persistent latent infection following acute infection. During latency, KSHV persists as episomes in the nucleus and expresses only a few latent genes including viral homologs of the cellular FADD-like interleukin-1- $\beta$ -converting enzyme (FLICE)/caspase-8-inhibitory protein (vFLIP) and cellular cyclin D (vCyclin), and latent nuclear antigen (LANA) encoded by ORF71, ORF72 and ORF73, respectively, from the so-called "latency locus" of its genome.<sup>1</sup> In KS lesions, the majority of the tumor cells are latently infected by KSHV, underscoring the essential role of this phase of viral lifecycle in tumor development. However, a small number of the infected cells also undergo spontaneous lytic replication. KSHV lytic replication and the resulting de novo infection produce viral

homologs of cytokines and induce cellular cytokines, all of which promote tumor inflammation and growth.<sup>1</sup> Thus, the mechanism of latency and reactivation is a central conundrum for KSHV biology and pathogenesis.

Significant advancement has been made towards understanding the molecular basis of KSHV lytic replication in the last decade. The replication and transcriptional activator (RTA) encoded by ORF50 is a key mediator of KSHV lytic replication. Activation of a number of cellular pathways such as mitogen-activated protein kinase (MAPK) pathways leads to the induction of RTA and lytic replication.<sup>1</sup> In contrast, less is known about the mechanism of KSHV latency. Similar to other herpesviruses, a successful latent infection requires not only the survival of latent cells and persistence of viral episome but also tight control of viral lytic replication. So far, the latent proteins have been shown to be essential for achieving KSHV latent status. LANA promotes KSHV latency by mediating efficient episome replication and proper segregation of the viral genomes into daughter cells during mitosis. As a result, genetic "knockout" of LANA prevents the establishment of latency and leads to a rapid loss of viral genomes.<sup>2</sup> LANA also promotes the growth and survival of latent cells by inhibiting p53 and pRb tumor suppressor pathways, and activating mitogenic/oncogenic c-Myc,  $\beta$ -catenin and MAPK pathways.<sup>1</sup> Furthermore, LANA controls viral lytic replication by epigenetic silencing of the KSHV genome and inhibition of RTA transactivation function. Indeed, the LANA deletion mutant has increased expression levels of RTA and lytic replication.<sup>3</sup>

KSHV vCyclin and vFLIP also promote viral latency. vCyclin promotes cell growth by accelerating cell cycle progression while vFLIP enhances cell survival by activating both canonical and noncanonical NF $\kappa$ B pathways.<sup>1</sup> Furthermore, vFLIP suppresses the AP-1 pathway to inhibit KSHV lytic replication program by activating the NF $\kappa$ B pathway.<sup>4</sup> Consequently, genetic deletion of vFLIP enhanced KSHV lytic replication while overexpression of vFLIP inhibits viral lytic replication.

microRNAs (miRNAs) are a class of ~22 nt long non-coding small RNAs that primarily regulate gene expression at the post-transcriptional level. miRNAs are involved in regulating diverse biological processes, including development, differentiation, metabolism, cancer and viral infection. The discovery of miRNAs encoded by herpesviruses indicates that this fundamental mode of gene regulation is also present in these viruses. Interestingly, the majority of herpesviral miRNAs are expressed during latency, implicating their potential role in this phase of viral lifecycle.<sup>5</sup> Indeed, a number of herpesviral miRNAs have been shown to promote latency by directly targeting the viral immediate-early genes to inhibit lytic replication of herpes simplex virus and human cytomegalovirus.<sup>5</sup> KSHV encodes 17 miRNAs derived from 12 pre-miRNAs, all of which are expressed from the latency locus. While a number of these miRNAs have been shown to target regulators of various cellular functions including cell survival, angiogenesis and cytokine secretion,<sup>6-11</sup> their role in KSHV latency and replication remains unknown. Since all KSHV miRNAs are expressed during latency, we hypothesized that they have important role in latency. We set up

\*Correspondence to: Shou-Jiang Gao; Email: gaos@uthscsa.edu

Submitted: 02/02/10; Accepted: 02/03/10

Previously published online: [www.landesbioscience.com/journals/cc/article/11387](http://www.landesbioscience.com/journals/cc/article/11387)

Comment on: Lei X, et al. Nat Cell Biol 2010; 12:193-9.

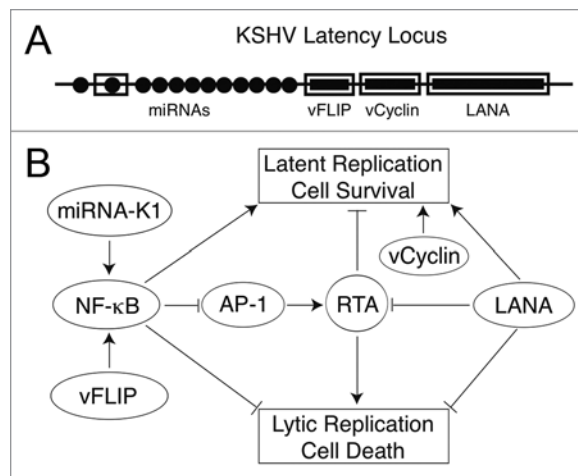

**Figure 1.** Multiple mechanisms regulate KSHV latency and cell survival. (A) Schematic illustration of KSHV latent genes and products located within the “latency locus” of the viral genome; (B) KSHV latent genes and products employ distinct mechanisms to promote viral latency. LANA maintains episome persistence, enhances cell growth, and inhibits lytic replication. vCyclin promotes cell growth by regulating cell cycle. Both vFLIP and miRNA-K1 target the NFκB pathway to inhibit KSHV lytic replication and promote cell survival.

experiments to interrogate their functions in KSHV lifecycle by generating a mutant virus with a deletion of a cluster of 10 pre-miRNAs encoding 14 of the 17 miRNAs.<sup>12</sup> Upon reconstitution in mammalian cells, we found that cells infected by the mutant virus expressed normal levels of latent genes but significant higher level of RTA and had an enhanced level of viral lytic replication than those infected by the wild-type virus. Interestingly, mutant virus-infected cells displayed a lower level of NFκB activity, which was correlated with a higher level of IκBα, a protein that inhibits NFκB activation. These results led to the hypothesis that viral miRNAs might target IκBα to promote cell survival and KSHV latency. Indeed, we found that one of the KSHV miRNAs, miRNA-K1, directly targets IκBα to enhance NFκB activation. Similar to the situation of vFLIP, miRNA-K1-mediated activation of NFκB pathway also led to the inhibition of RTA expression and viral lytic replication. Thus, unlike other herpesviral miRNAs, our results define a novel regulatory mechanism of viral latency and lytic replication for KSHV miRNAs, i.e., by “hijacking” a host survival pathway.<sup>12</sup> At the same time

when our study was published, two other independent studies also reported inhibition of viral lytic replication by KSHV miRNAs. In the first study, miRNA-K9\* was shown to target RTA.<sup>13</sup> In the second study, miRNA-K4-5p was shown to epigenetically repress RTA expression by targeting Retinoblastoma (Rb)-like protein 2, a transcriptional repressor of DNA methyl transferases 1, 3a and 3b.<sup>14</sup> These results, together with the known functions of other viral latent genes, indicate that the mechanism of KSHV latency is complex, involving multiple viral products and pathways.

The identification of NFκB pathway as a target of a KSHV miRNA<sup>12</sup> is intriguing as it is a cellular pathway involved in the latency of several gammaherpesviruses, as well as in immunity, inflammation and tumor development. The mechanism by which miRNA-K1 activates NFκB pathway is also distinct from that of vFLIP, which activates the same pathway by interacting with IKKγ. Nevertheless, the outcome is the same in that both control KSHV latency by suppressing lytic replication and promoting cell survival, a task that seems to be fulfilled by all

products encoded by the viral “latency locus” as summarized in **Figure 1**. Thus, our results have provided further insights into the mechanism KSHV latency and reactivation.

#### Acknowledgements

This work was supported by grants from American Cancer Society (#RSG-04-195) and National Institute of Health (CA096512, CA124332, CA132637 and DE017333) to S.J.G., and the National Science Foundation (CCF-0546345) to Y.F.H.

#### References

- Greene W, et al. *Cancer Treat Res* 2007; 133:69-127.
- Ye FC, et al. *J Virol* 2004; 78:11121-9.
- Li Q, et al. *Virology* 2008; 379:234-44.
- Ye FC, et al. *J Virol* 2008; 82:4235-49.
- Cullen BR. *Nature* 2009; 457:421-5.
- Gottwein E, et al. *Nature* 2007; 450:1096-9.
- Skalsky RL, et al. *J Virol* 2007; 81:12836-45.
- Samols MA, et al. *PLoS Pathog* 2007; 3:65.
- Nachmani D, et al. *Cell Host Microbe* 2009; 5:376-85.
- Ziegelbauer JM, et al. *Nat Genet* 2009; 41:130-4.
- Qin Z, et al. *J Leukoc Biol* 2010; 87:25-34.
- Lei X, et al. *Nat Cell Biol* 2010; 12:193-9.
- Bellare P, Ganem D. *Cell Host Microbe* 2009; 6:570-5.
- Lu F, et al. *J Virol* 2010; Epub ahead of print.